

Compact Series

Linear Guide Systems

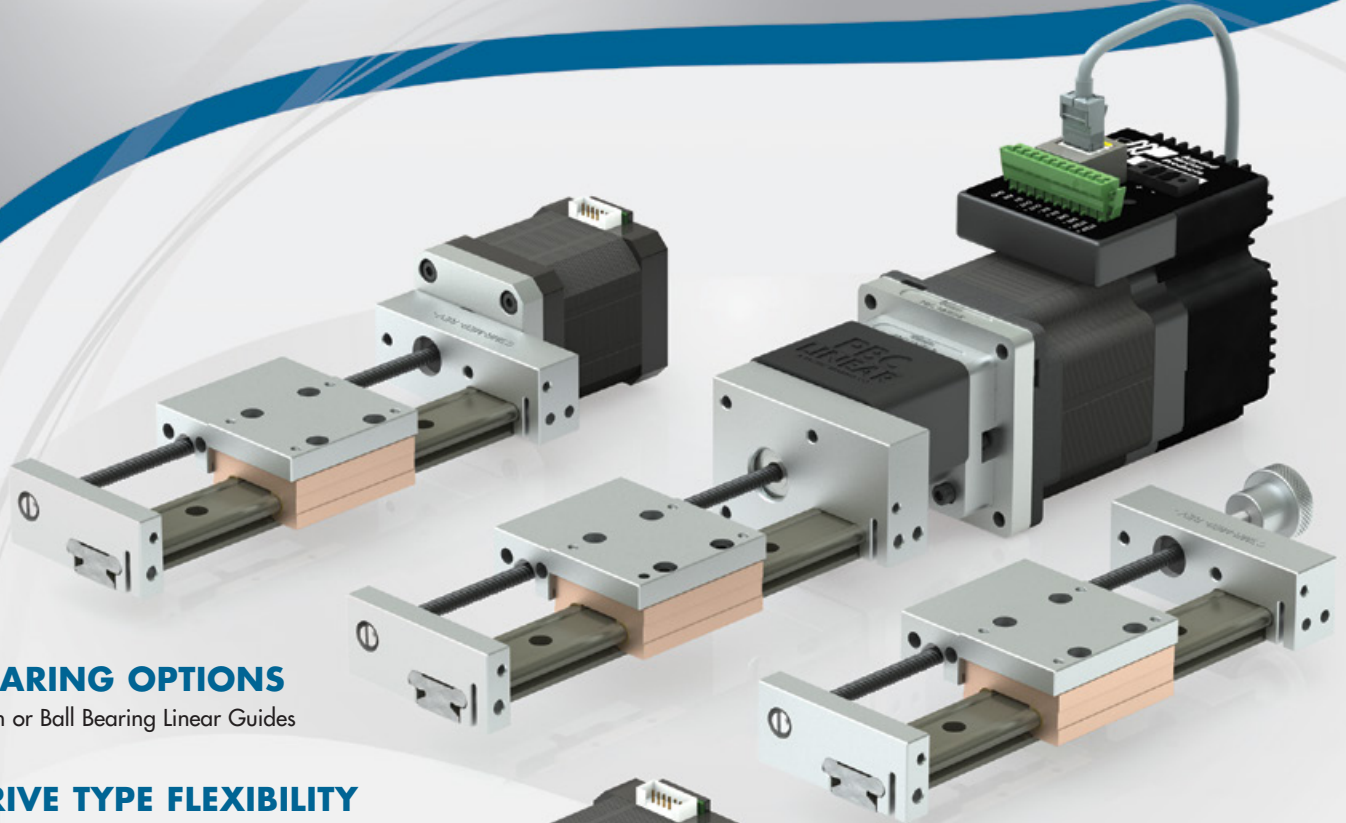
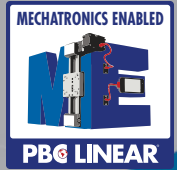

BEARING OPTIONS

Plain or Ball Bearing Linear Guides

DRIVE TYPE FLEXIBILITY

- Integrated Stepper Motor
- Motor Mount
- Manual

COMPACT

23 mm Low Profile

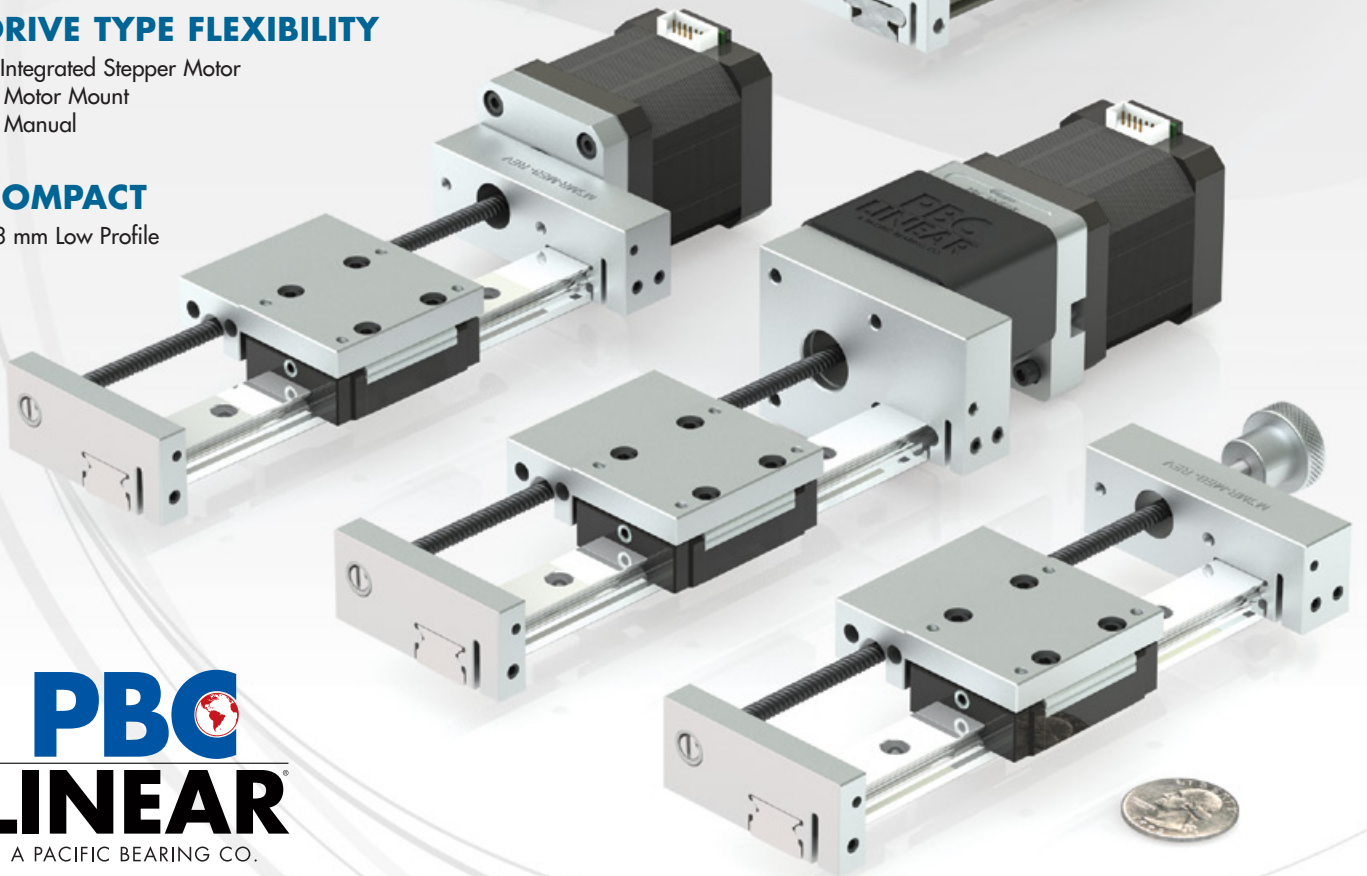

A PACIFIC BEARING CO.

1-800-962-8979

www.pbclinear.com



Bearing System Options

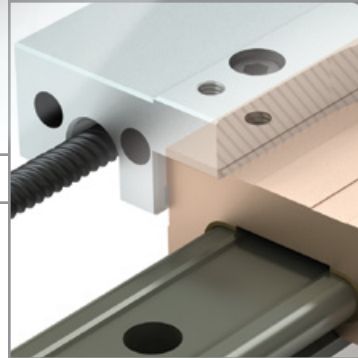
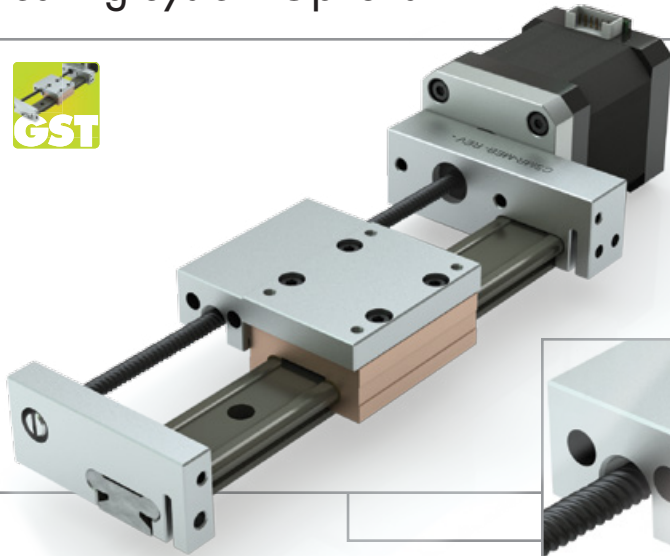

Gliding Surface Technology Plain Bearing with FrelonGOLD®

- LOW COST
- Self-lubricating design
 - No sealing
 - No particulates
- Tolerates temperature extremes
- Corrosion-resistant
- Industry standard interchangeable
- Vibration damping
- Suitable for an extremely short stroke



Technical Specifications – Page 10

Lead Screw Options

- 6 mm and 10 mm diameter lead screw
- Self-lubricating PTFE coated



Nut Options

- Constant Force™ anti-backlash nut
- Standard fixed nut
- Good rigidity and vibration damping
- Self-lubricating and maintenance free

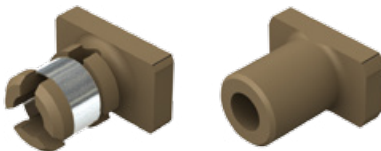

Compact Series Linear Guide Systems

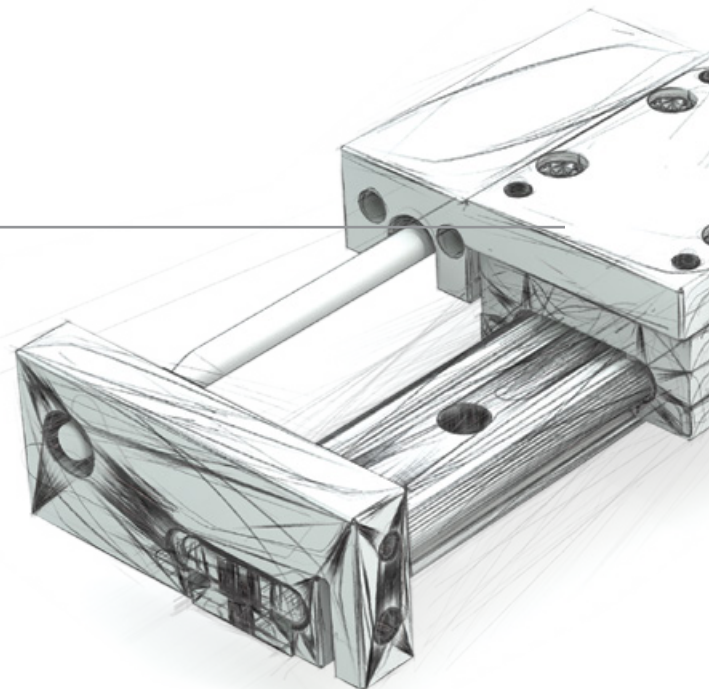



Bearing System Options

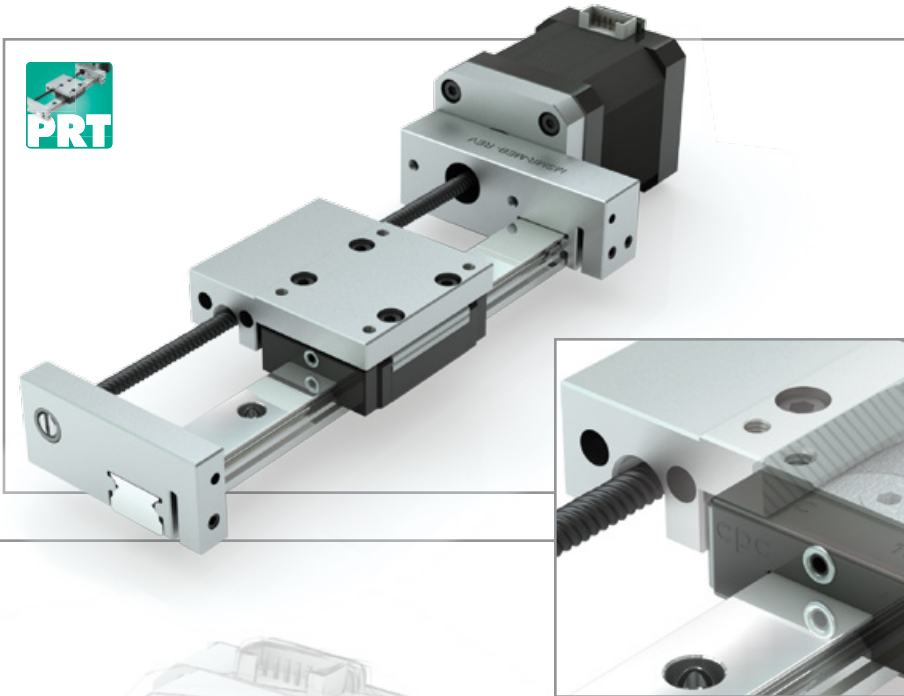

Profile Rail Technology Ball Bearing Linear Guides

- HIGH RIGIDITY & PRECISION
- High load and moment capacity
- Dust proof design
- Suitable for high speeds
- Supports cantilevered loads
- Low coefficient of friction

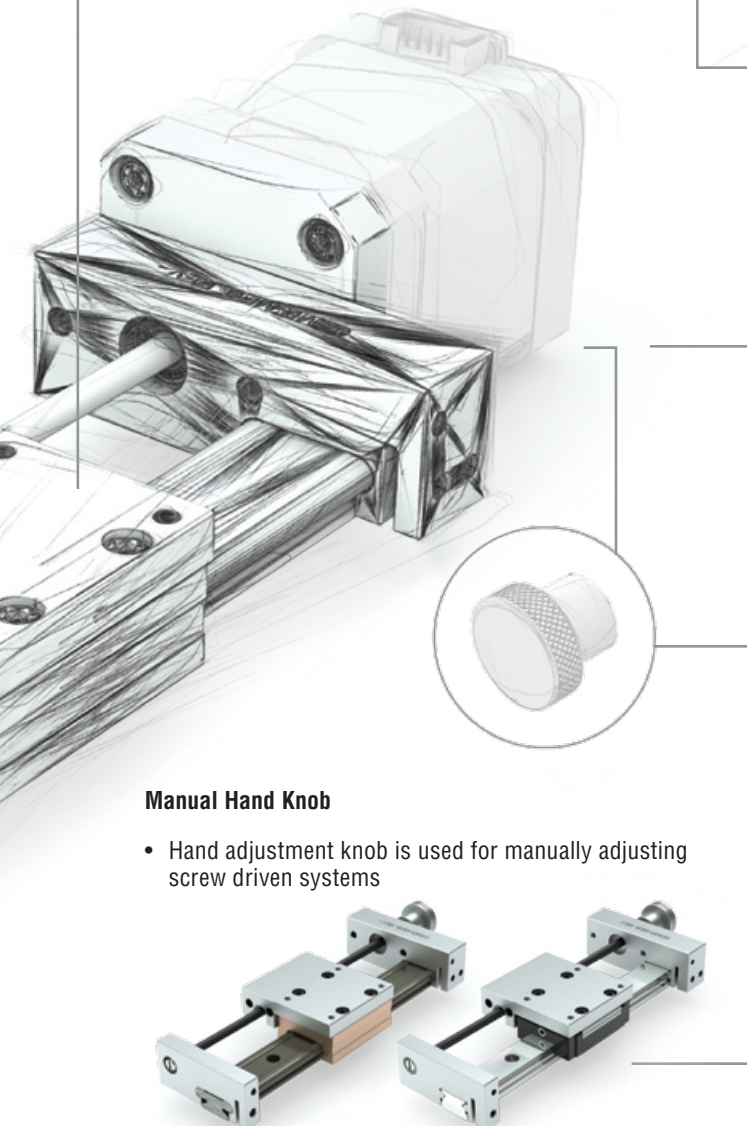

Manual Hand Knob

- Hand adjustment knob is used for manually adjusting screw driven systems

Drive Type Flexibility

Integrated Stepper Motor

- NEMA 17 or NEMA 23 motors
- Lead screw aligned and fixed directly with motor
- Fewer components means greater accuracy and increased rigidity

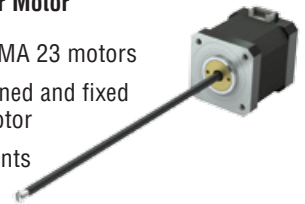

Motor Mount

- Attach stepper, servo, or smart motor
- Compatible with NEMA 17 and NEMA 23 motor sizes
- One-piece main frame holds shaft-to-shaft centerline
- Easily attached with adapter plate and coupler
- Assembled system available with motor and motor mount, consult factory





Applications

MEDICAL AND LABORATORY EQUIPMENT:

The self-lubricating FrelonGOLD® bearing liner, in the plain bearing option of the Compact Series, is ideal for environments where no grease or lubrication can be present.

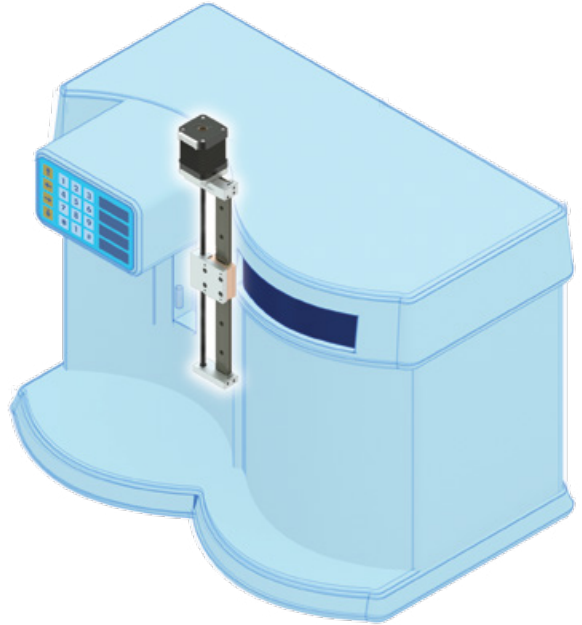
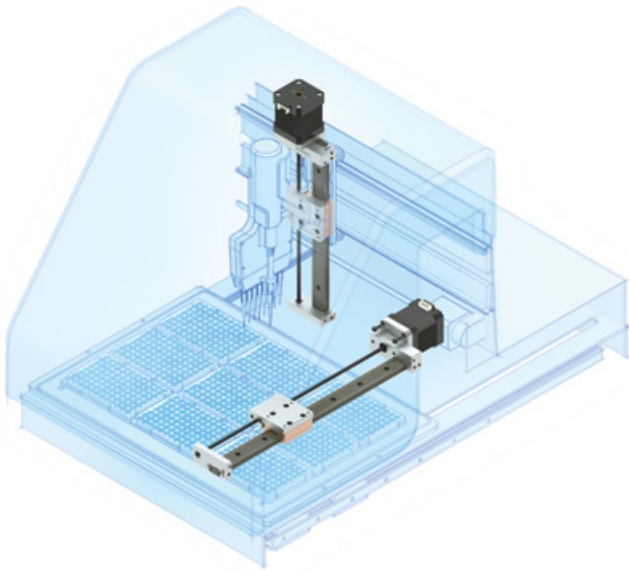

WELL PLATE HANDLING: Compact Series installed in an intricate well plate handler—providing accurate and reliable linear motion.

AUTOMATED CONVEYOR: Material handling conveyor systems utilize the Compact Series linear guide system for maintenance free, repeatable linear motion.

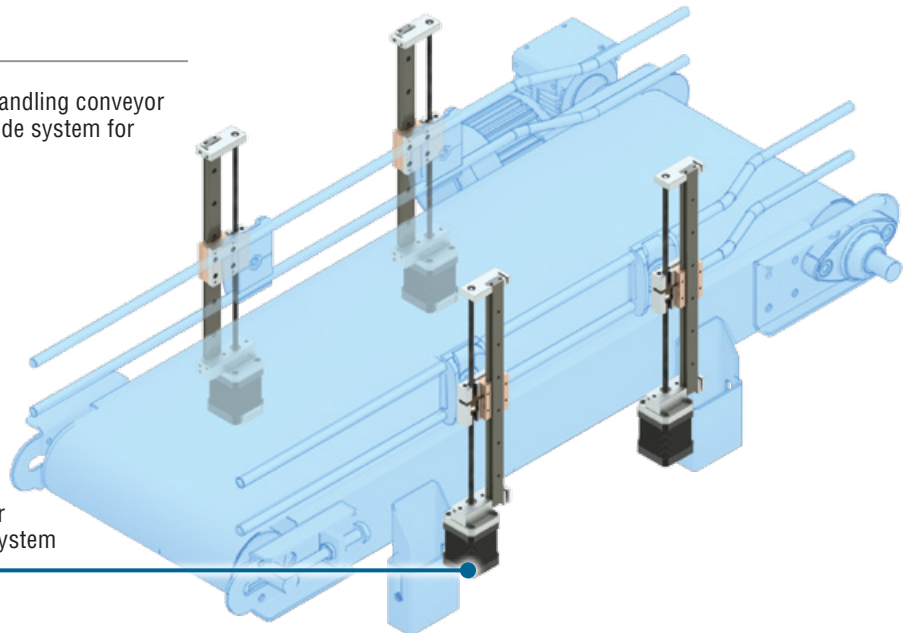

Integrated stepper motor reduces the number of components and improves rigidity in the system



Applications

SCANNING EQUIPMENT: High precision and smooth operation are required when designing linear motion for laboratory scanning equipment. The plain bearing system utilizes FrelonGOLD®—a self-lubricating, maintenance free surface that does not require oil.

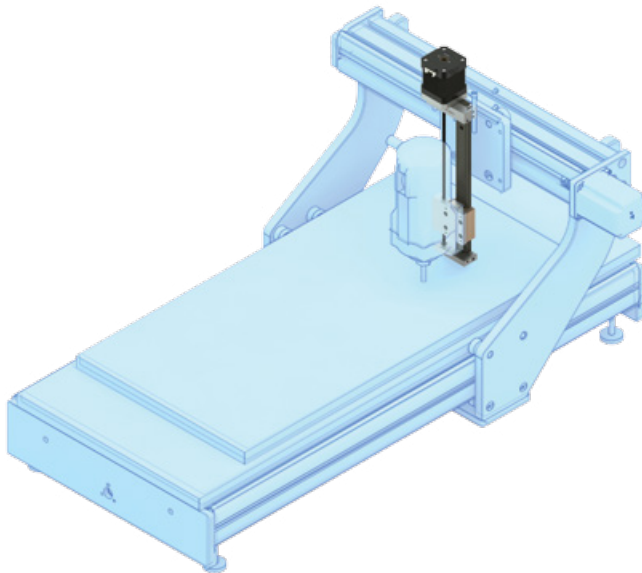
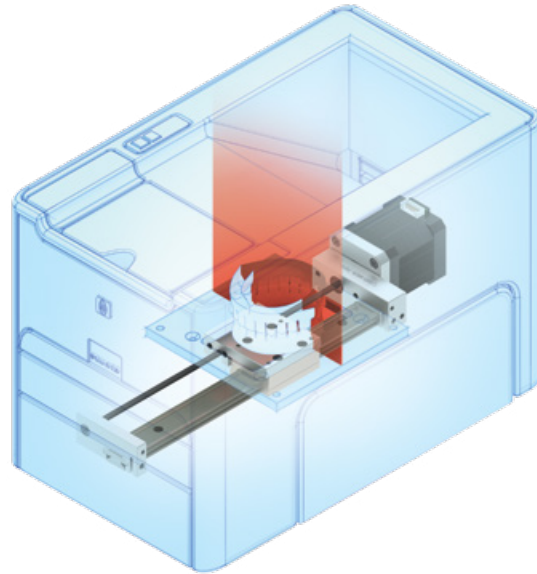

CNC ROUTER: The plain bearing version of the Compact Series is ideal for harsh, dirty environments such as a CNC router. The carriage acts as a wiper as it clears away contamination such as dust and debris from the rail.

Plain bearings utilize the bonded FrelonGold® self-lubricating maintenance-free surface

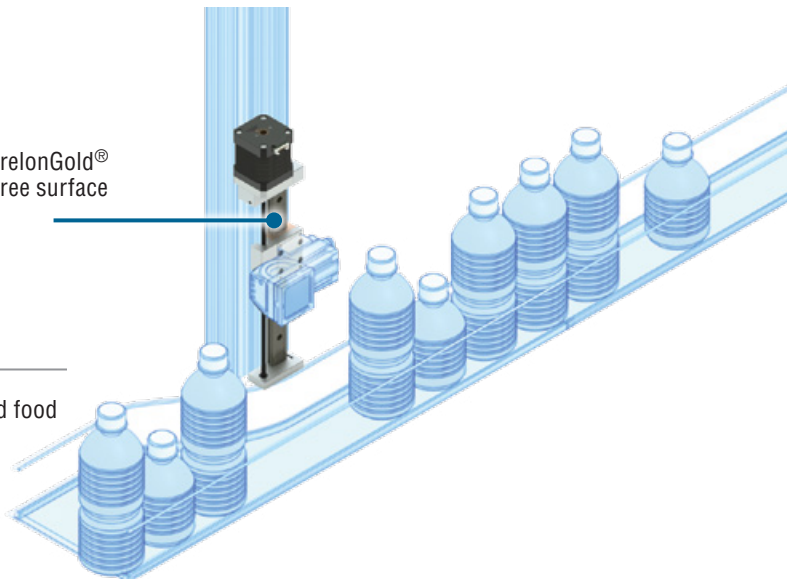

BOTTLING: The Compact Series is ideal in bottling and food service applications that require repeatable motion and involve various load capacities.



Three Steps to Design It Your Way

Step 1: Bearing System

Page 5

Gliding Surface Technology
Plain Bearings

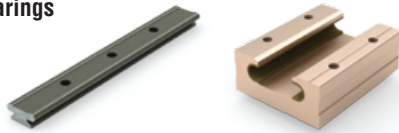

Profile Rail Technology
Ball Bearings

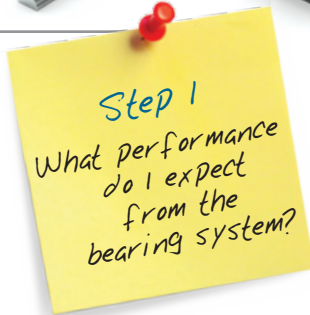

Step 2: Lead Screw & Nut

Page 6

Screw Diameters

- 6 mm
- 10 mm

Nut Options:

- Constant Force™ anti-backlash nut
- Standard fixed nut



Step 3: Motor & Drive Type - NEMA 17 or NEMA 23

Page 7

Integrated Screw & Motor

- Lead screw aligned and fixed directly with motor

Motor Mount

- Attach any stepper, servo, or smart motor

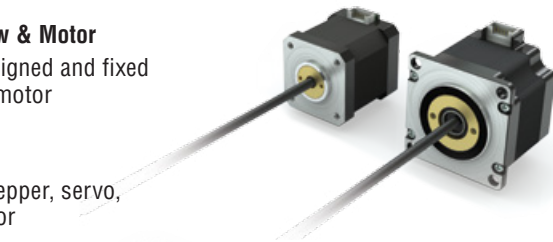

Manual Hand Knob

- Hand knob for manually adjusting screw driven system



Design It Your Way 4

 Step 1: Bearing System Selection 5

 Step 2: Lead Screw & Nut Options 6

 Step 3: Drive Type Selection 7

Bearing Features & Benefits

 GST – Plain Bearings 8

 PRT – Ball Bearings 9

System Specifications

 Dimensions 10

 Performance Charts 12

 Ordering 13

Motor Mounts

 Specifications and Ordering 15

 Dimensions 16

User Manual 18

If you are utilizing our digital Compact Series catalog, you can click these icons, throughout the publication, to get more information. *Hyperlinks go to English language website.*





Bearing System Selection

Step 1

Step 2

Step 3



Gliding Surface Technology

PLAIN BEARING

- Low cost
- Utilizes bonded **FrelonGOLD®** bearing surfaces
- Self-lubricating and maintenance free
- No catastrophic failure
- No metal-to-metal contact, vibration damping
- Wide temperature range
- Resists contamination
- 510 mm maximum length

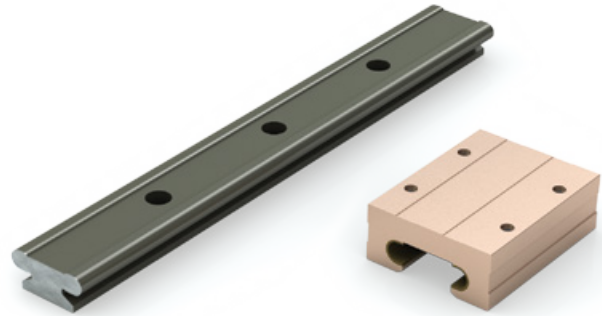

Note: Plain bearings should comply with the 2:1 ratio rule.



[System Ordering Information—Page 13](#)



[White Paper Link: Demystifying the 2:1 Ratio](#)



Profile Rail Technology

BALL BEARING LINEAR GUIDES

- High precision and high speeds
- Size 15 mm bearing block
- Rigid and precise recirculating ball design
- Increased stiffness and preloaded bearing performance
- Supports cantilevered loads
- Low coefficient of friction
- Upgrade to high precision carriage upon availability
- 510 mm maximum length

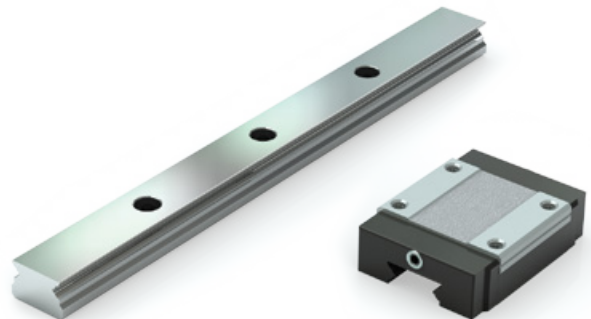

[System Ordering Information—Page 13](#)

**UNIFORM DIMENSIONING
PROVIDES DESIGN FLEXIBILITY.**



Step 1

Lead Screw & Nut Options

Step 2

LEAD SCREW OPTIONS

- 6 mm and 10 mm diameter lead screw
- Self-lubricating PTFE coated
- 1, 2, 5, 10 mm leads most common
- Other leads available—consult factory

Step 3

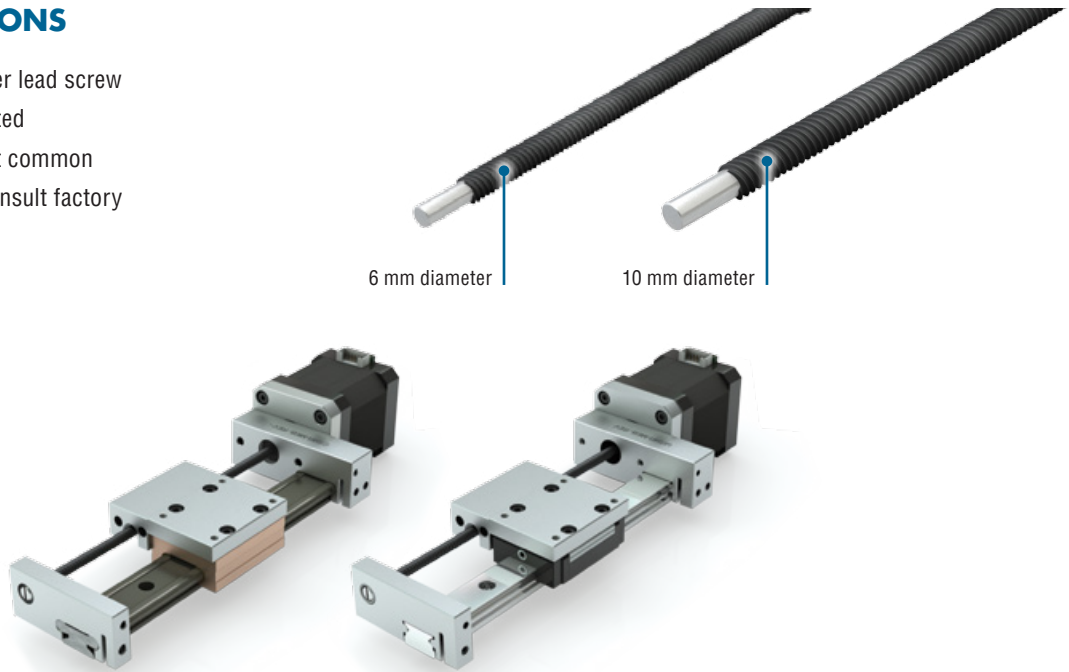

Consult Factory for 10 mm Diameter Screw System • 800-962-8979

NUT OPTIONS

Constant Force™ Anti-Backlash Nut

An intuitive leap forward in nut design for lead screw applications, Constant Force Technology utilizes a constant force spring to apply a uniform pressure to the nut at all stages of the motion profile.

- Greater consistency and resistance to backlash
- Configurable for various torque requirements
- Patent pending self-adjusting anti-backlash feature
- Polymer nuts are self-lubricating and maintenance free

Standard Fixed Nut

- Good rigidity and vibration damping
- Polymer nuts are self-lubricating and maintenance free

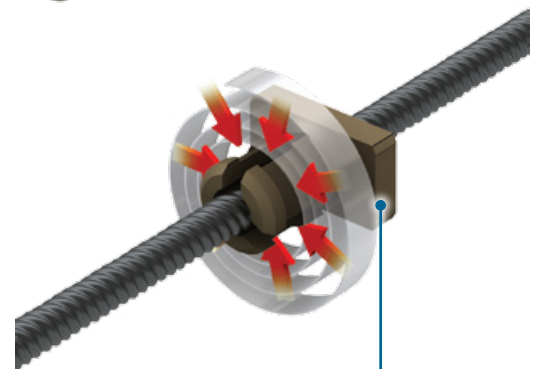
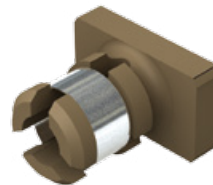
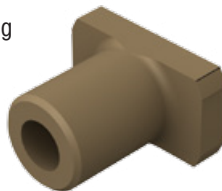

Patent pending Constant Force Technology nut provides consistent anti-backlash operation



[Video Link: Screws, Nuts, and Hybrid Linear Actuators](#)



Motor Type Selection

Step 1

Step 2

Step 3

INTEGRATED STEPPER MOTOR

- Lead screw aligned and fixed directly with motor
- Fewer components means greater accuracy, increased rigidity, and less cost
- 6 mm and 10 mm diameter lead screw driven
- NEMA 17 and NEMA 23 motors
- Single and double stack
- Standard wire connection is onboard plug—included connector plug with 12" leads
- Longer leads available, consult factory

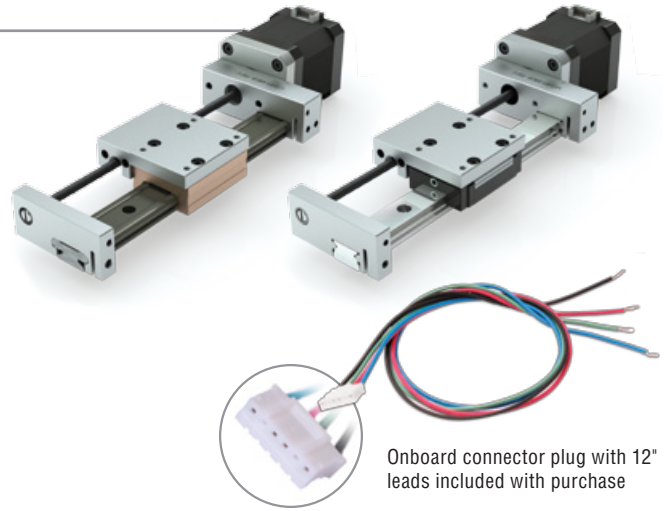
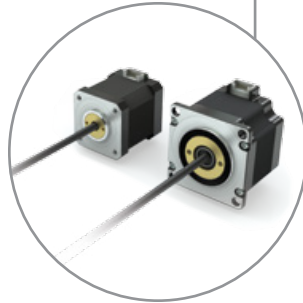

Onboard connector plug with 12" leads included with purchase

[System Ordering Information—Page 13](#)

MOTOR MOUNT

- One-piece main frame holds shaft-to-shaft centerline
 - Extends motor and coupler life
 - Increases accuracy and repeatability
- Attach NEMA 17 or NEMA 23 stepper, servo, or smart motor
- 6 mm and 10 mm diameter lead screw driven
- Easy to assemble
- Easily attached with adapter plate and coupler
- Assembled system available with motor and motor mount, consult factory

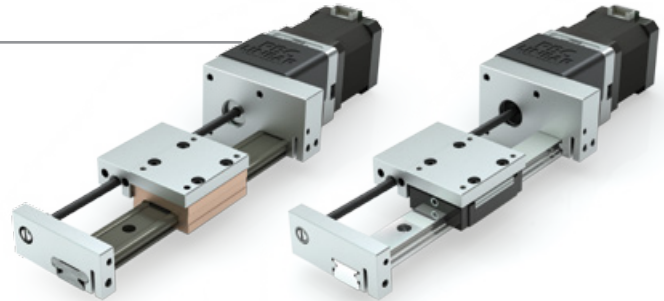
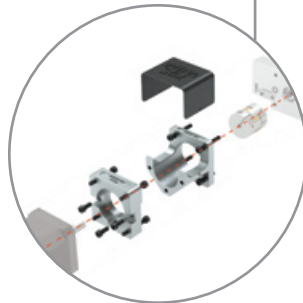
[Motor Mount Details—Page 15](#)

MANUAL HAND KNOB

- Hand adjustment knob is used for manually adjusting screw driven systems

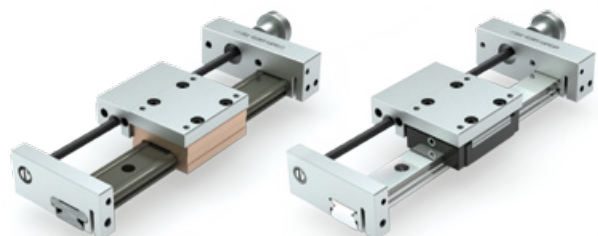



Bearing System Gliding Surface Technology



Gliding Surface Technology

PLAIN BEARING

OVERVIEW

- Low—23 mm—profile design
- 510 mm maximum length
- Size 15 mm bearing block
- Utilizes the bonded **FrelonGOLD®** self-lubricating and maintenance free bearing surfaces
- Smooth and quiet operation
- Vibration damping and shock resistant

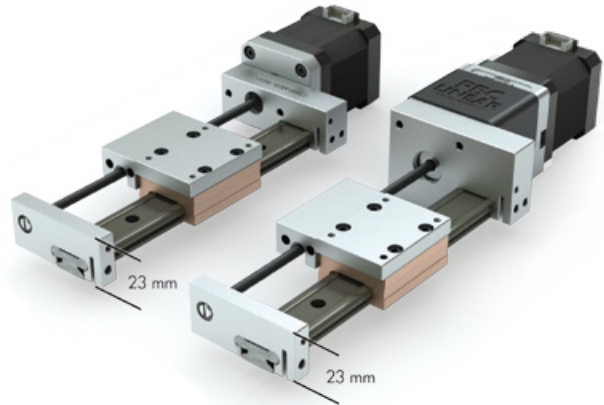

LEAD SCREW & NUT

- Lead screw 6 mm and 10 mm diameter, consult factory for 10 mm
- 300 series stainless steel with PTFE coating
- 1, 2, 5, 10 mm leads most common
- Other leads available—consult factory
- Constant Force™ anti-backlash or standard fixed nut

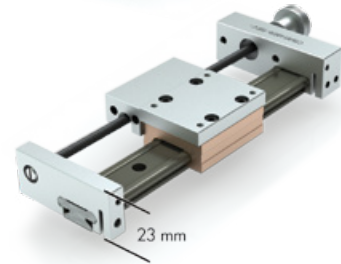

MOTOR & DRIVE TYPE

Integrated Stepper Motor

- Integrated lead screw eliminates components and tolerance stack-ups
- Improved rigidity and performance
- Reduced system costs
- Connector with 12" flying leads included

Motor Mount

- Designed to work optimally with R+W EKL2 coupler

Manual Hand knobs

- Hand adjustment knob is used for manually adjusting screw driven systems



[System Ordering Information—Page 13](#)



[Motor Mount Details—Page 15](#)



Profile Rail Technology **Bearing System**



Profile Rail Technology

BALL BEARING LINEAR GUIDES

OVERVIEW

- Low—23 mm—profile design
- 510 mm maximum length
- Size 15 mm bearing block
- High precision, rigidity, and speeds
- Increased stiffness and preloaded bearing performance
- Supports cantilevered loads
- Low coefficient of friction
- Upgrade to high precision carriage upon availability

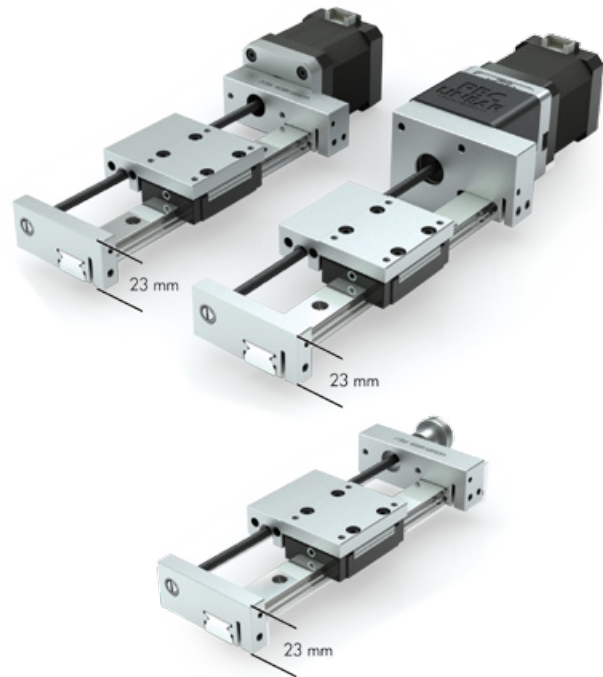

LEAD SCREW & NUT

- Lead screw 6 mm and 10 mm diameter, consult factory for 10 mm
- 300 series stainless steel with PTFE coating
- 1, 2, 5, 10 mm leads most common
- Other leads available—consult factory
- Constant Force™ anti-backlash or standard fixed nut

MOTOR & DRIVE TYPE

Integrated Stepper Motor

- Integrated lead screw eliminates components and tolerance stack-ups
- Improved rigidity and performance
- Reduced system costs
- Connector with 12" flying leads included

Motor Mount

- Designed to work optimally with R+W EKL2 coupler

Manual Hand knobs

- Hand adjustment knob is used for manually adjusting screw driven systems

[System Ordering Information—Page 13](#)[Motor Mount Details—Page 15](#)



Dimensions GST & PRT System

SYSTEM DIMENSIONS

6 mm screw system shown

TOP VIEW

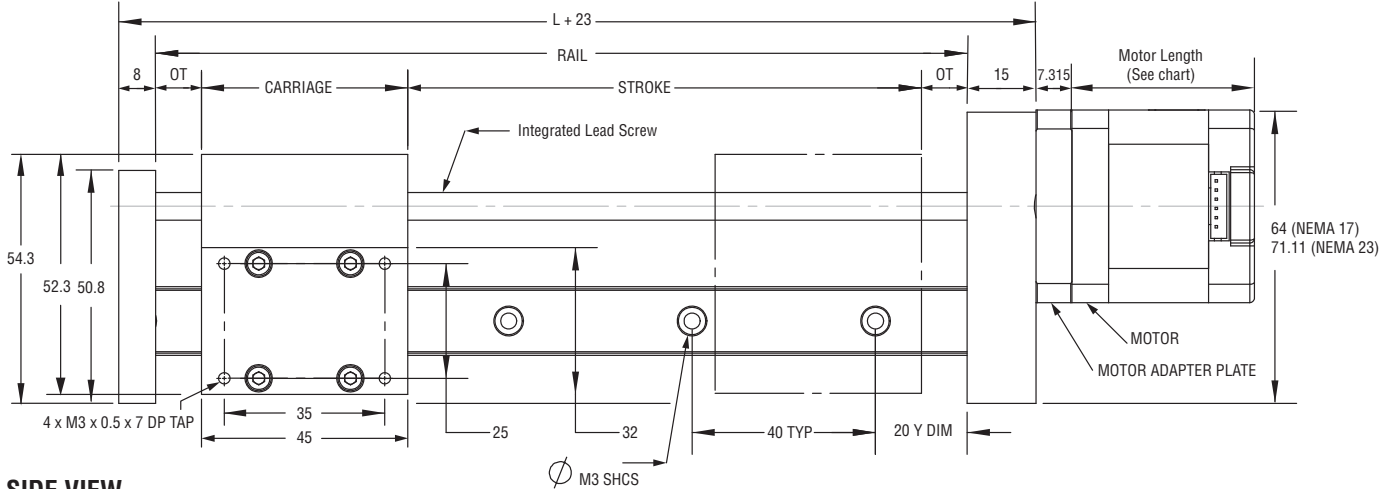

SIDE VIEW

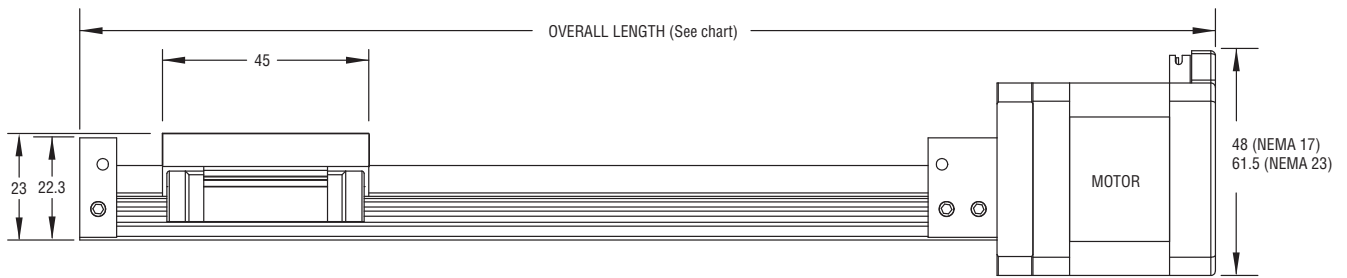

Consult Factory for 10 mm Diameter Screw System • 800-962-8979



Email an Application Engineer

CARRIAGE DETAIL

1:1 Shown

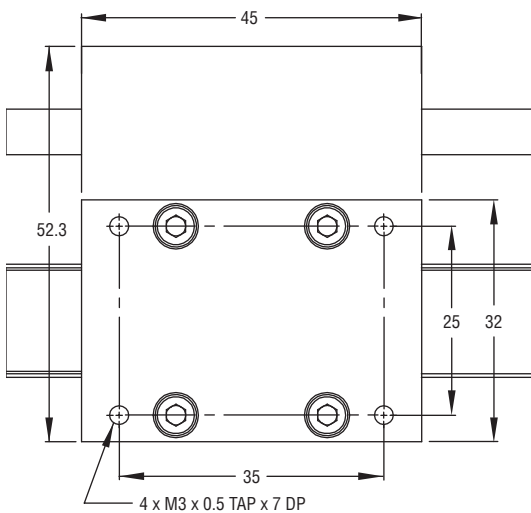

MOTOR END VIEW (WITH MOTOR MOUNT)

6 mm screw system shown

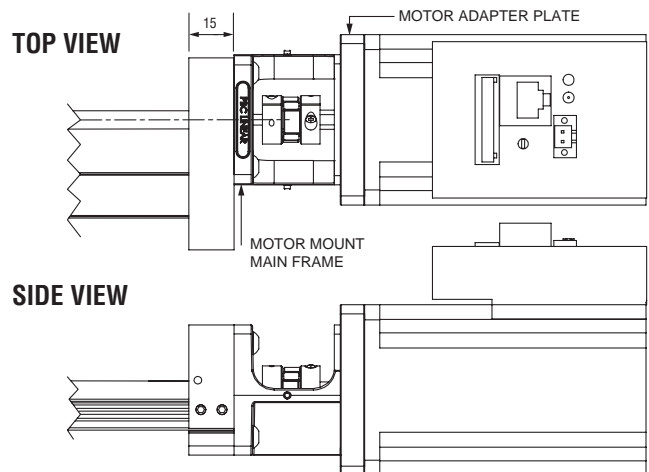



Overall System Length

MOTOR LENGTHS (PLUS MOUNTING PLATE)

Motor Size	Single Stack	Double Stack
NEMA 17	39.8 mm	48.3 mm
NEMA 23	57 mm	79 mm

Note: Overall length calculations should include 7.8 mm width for motor mounting plate.

OVERALL LENGTH CALCULATION

$$\begin{aligned}
 &\text{Over-Travel Drive End} = \underline{\hspace{2cm}} \text{ mm} \\
 &\quad + \text{Carriage} = \underline{\hspace{1cm} 45 \hspace{1cm}} \text{ mm} \\
 &\quad + \text{Stroke} = \underline{\hspace{2cm}} \text{ mm} \\
 &+ \text{Over-Travel Idle End} = \underline{\hspace{2cm}} \text{ mm} \\
 &\quad \underline{\hspace{2cm}} \\
 &\quad = \text{*Rail} = \underline{\hspace{2cm}} \text{ mm} \\
 &\quad + \text{End Blocks} = \underline{\hspace{1cm} 23 (8 + 15) \hspace{1cm}} \text{ mm} \\
 &+ \text{Motor \& Mounting} \\
 &\quad \text{Plate Length} = \underline{\hspace{2cm}} \text{ mm} \\
 &\quad \underline{\hspace{2cm}} \\
 &= \text{Overall Length} = \underline{\hspace{2cm}} \text{ mm}
 \end{aligned}$$

* Rail dimension is specified at time of order



Consult Factory for 10 mm Diameter Screw System • 800-962-8979

**Recommended Minimum Overtravel (OT)
for Compact Series Systems = 10 mm**

ONBOARD CONNECTOR PLUG

With 12" Leads Included with Purchase

NEMA 17 Connector
PBC Part Number: 6200490

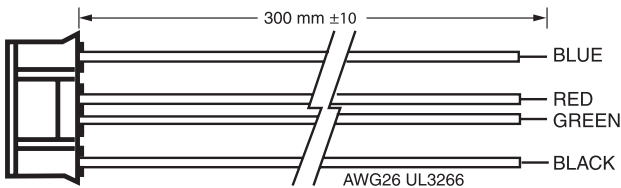

Housing: JST PHR-6
Terminal: JST SPH-002T-P0.5

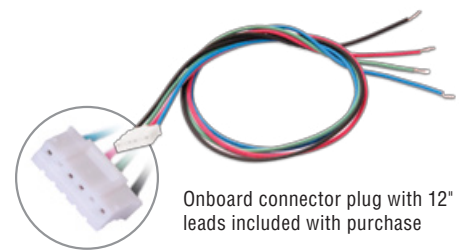

NEMA 23 Connector
PBC Part Number: 6200491

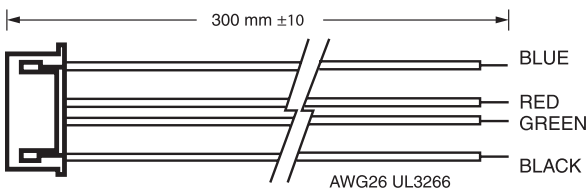

Housing: JST XHP-6
Terminal: JST SXH-001T-P0.6



Performance Charts

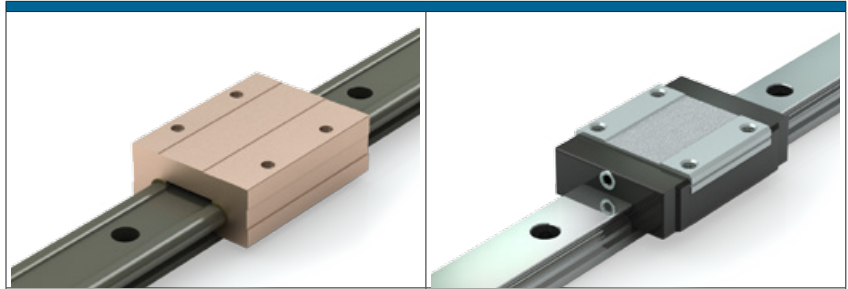
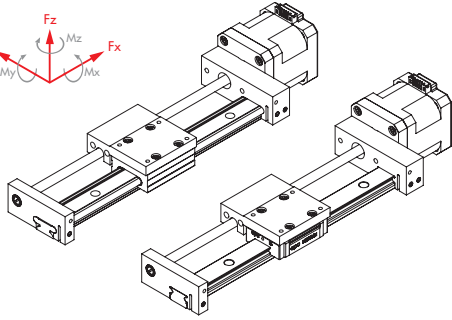
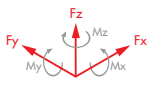

GLIDING SURFACE TECHNOLOGY
Plain Bearing

PROFILE RAIL TECHNOLOGY
Ball Bearing Linear Guides

Basic System Properties			
Max Velocity, no lube, continuous motion	m/s	1.5	3 (requires lubrication)
Max Velocity, intermittent motion	m/s	4.2 (with lubrication)	5.5 (requires lubrication)
Max Acceleration**	m/s ²	50	250
Stroke Length (min recommended – max)**	mm	5 - 440	5 - 440
Normal Operating Temperatures (min - max)	°C	0° - 80°C	
Max Drive (input) Speed	rpm	2000	
Standard Lead Screw Accuracy		ISO Class 10 (± .21 mm/300 mm)	
Carriage Weight (including four SHCS)	Kg	0.088	0.115
Rail + Screw Weight	Kg/mm	0.00058	0.00112
System Weight (excluding motor)	Kg	0.175 + (0.00058/mm * length)	0.242 + (0.00112/mm * length)
Static & Dynamic System Properties			
Max Static Load* (Supported Rail) Carriage Capacity Only	Fx	N	25
	Fy		667
	Fz (Normal)		3114
	Fz (Inverted)		356
Max Dynamic Load of System* (For PBC supplied motor, refer to charts below)	Fx	N	25
	Fy		240
	Fz (Normal)		240
	Fz (Inverted)		240
Max Moments*	Mx	Nm	9.0
	My		9.0
	Mz		15.1

* The above moments and loads are MAX values, please consult our technical department for further information.

** Increased acceleration may be possible in limited cases. Consult factory if exceeding limit.

BUCKLING COLUMN LOAD CURVE

6 mm diameter lead screw

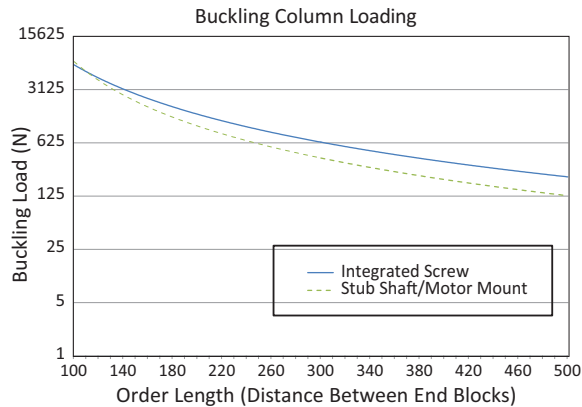

Note: Based on 500 mm stroke, GST version with .125 C.O.F. and .3G acceleration.
Based on 24 volt, but higher voltage amplifiers may produce higher speeds.



Ordering Information

CS	XX	15	D	XX	X	XXXX	X	XX	XX	XR	X	0
Series	Rail Type	Rail Width	Order Type	Carriage Preload	Accuracy	Rail Length	Drive End Option	Motor Option	Lead mm	Nut	Other Options	
Compact Series	MR Gliding Surface Technology Plain Bearing	15 mm	D Driven	00 GST Precision	0 GST Rail	510 mm max Consult factory for longer lengths	1 Stub Shaft Only	00 No Motor / Stub Shaft Only	AJ - 10 AX - 5 AG - 2 AH - 1 Consult factory for other leads	1 Standard 2 Constant Force Anti-Backlash	0 * Consult factory for other options such as encoder	
	PR Profile Rail Technology Ball Bearing			V0 PRT Clearance	N PRT Normal		3 Integrated Motor Screw	A1 NEMA 17 (42 mm) Single Stack A2 NEMA 17 (42 mm) Double Stack B4 NEMA 23 (56 mm) Single Stack				
				V1 PRT Light Preload	H PRT High		1 Stub Shaft Only	ZZ No Motor / Stub Shaft with Assembled Motor Mount*				

Ordering example: CSMR15D-000-0500-3A1-AHXR2-0.

* Motor mount is ordered separately. See page 15 for motor mount ordering details.



Consult Factory for 10 mm Diameter Screw System • 800-962-8979



Email an Application Engineer

VELOCITY LOAD CURVES HORIZONTAL

6 mm and 10 mm diameter lead screw

NEMA 17

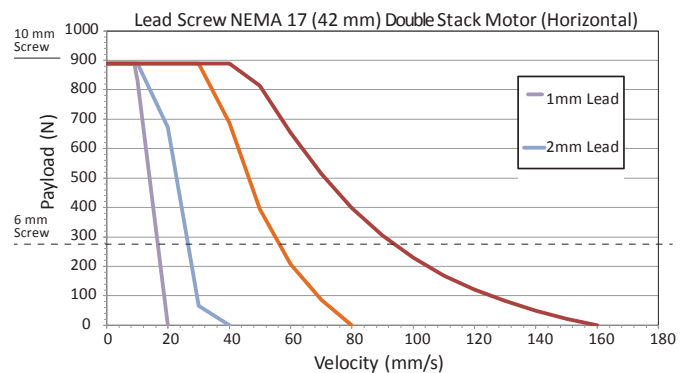
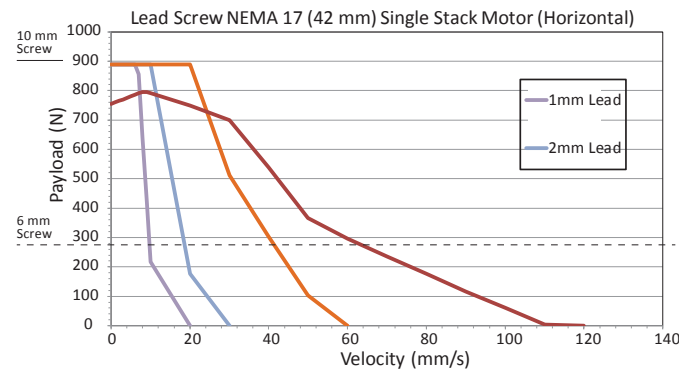

NEMA 23

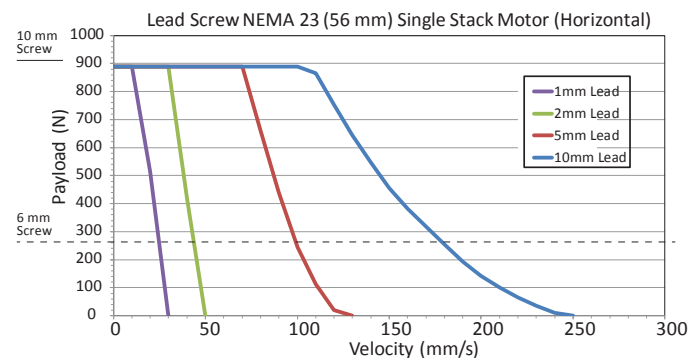



Motor Mount Option Benefits

PBC LINEAR'S DESIGN WITH PRE-ENGINEERED ALIGNMENT

- One-piece main frame holds shaft-to-shaft centerline
- Extends motor and coupler life
- Increases accuracy and repeatability
- Easy to assemble

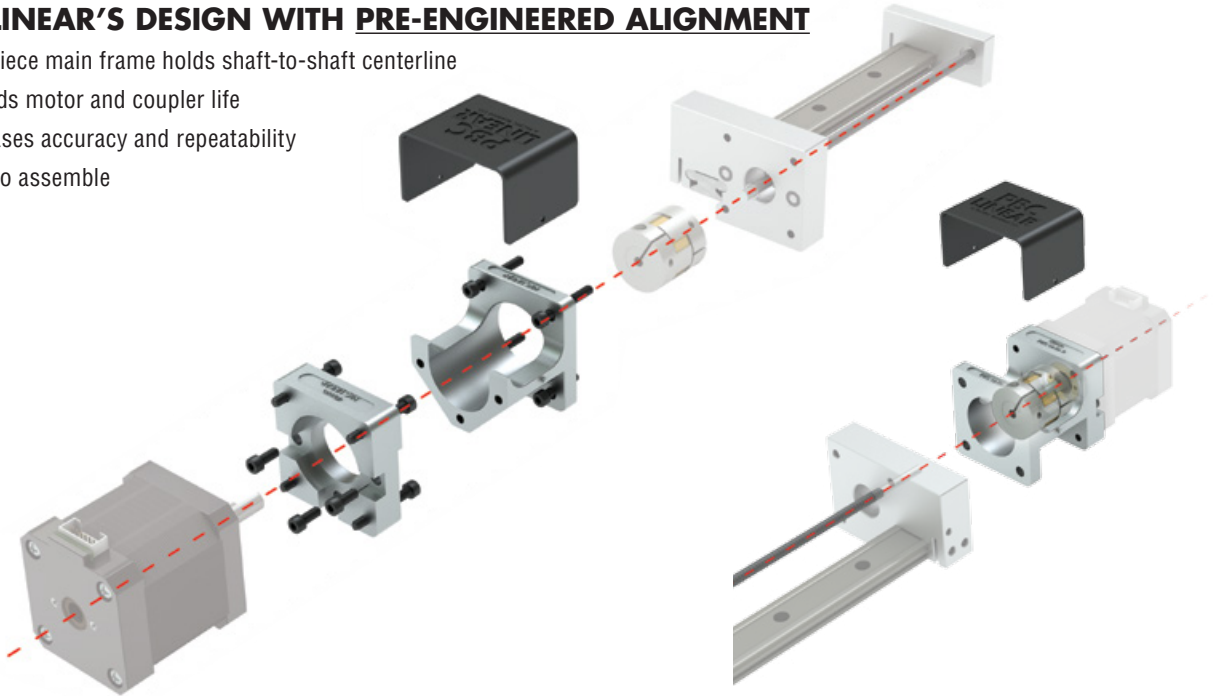

PBC LINEAR'S DESIGN VS. ALTERNATE DESIGNS

PROBLEMATIC DESIGNS CAUSE MIS-ALIGNMENT

- Mis-alignment between motor shaft, coupler, and screw shortens life and affects motion quality
- Mis-alignment results in camming or lobbing motion that translates to inconsistent linear movement
- Difficult to align and prone to deflection
- Over-torque of coupler causes accuracy loss



PROBLEM #1: DEFLECTION

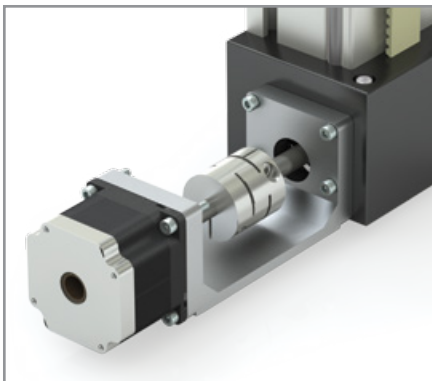

PROBLEM #2: TWIST

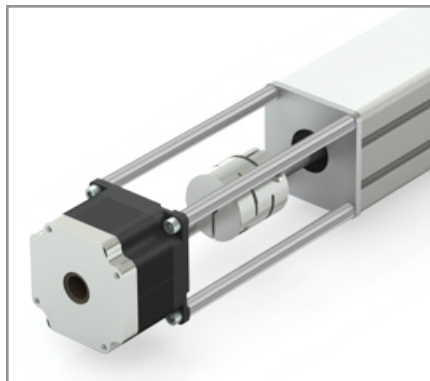

PROBLEM #3: OFF CENTERLINE

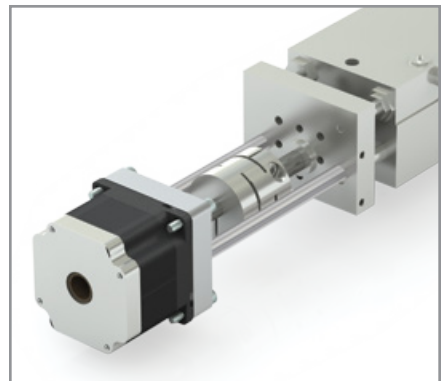



Ordering **Motor Mount Option**

Compact Series System Gliding Surface Technology – Plain Bearing Profile Rail Technology – Ball Bearings	Motor Size	Part Number	Recommended Coupler Ordered Separately or Customer Supplied	Included with Motor Mount Purchase
	NEMA 17 42 mm	UGA040A-3PMM-HF	R + W EKL2 Maximum coupler dimensions: 25 mm O.D. x 26 mm length	(1) Main frame with 4 SBHCS (Socket Button Head Cap Screw) (1) Motor plate with 3 SBHCS for attaching to frame* (1) Cover (plastic) * Customer supplies motor screws
	NEMA 23 56 mm	UGA040A-3PMM-HG		
	Blank Plate (customer machined)	UGA040A-3PMM-H0		

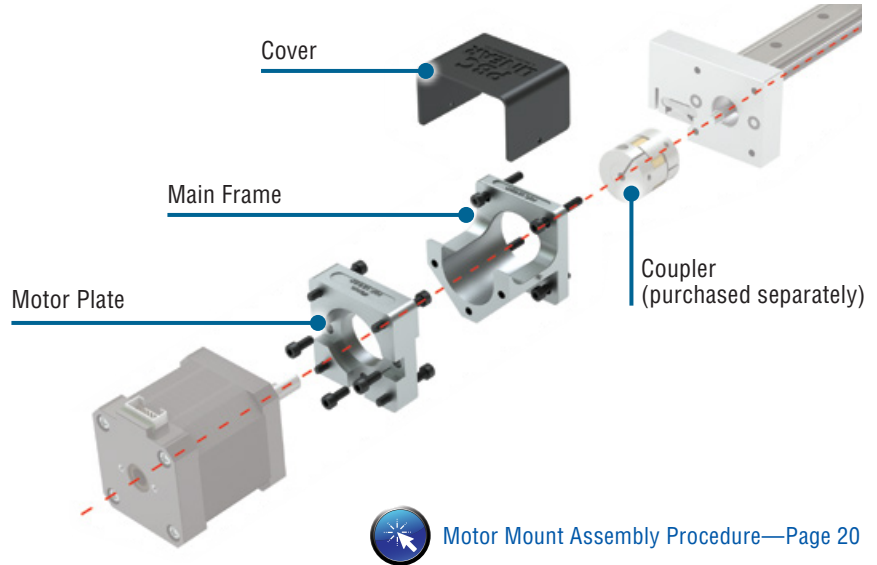

STUB SHAFT DIMENSIONS

Stub Shaft Diameter	3.5 mm
Overall Stub Shaft Length	15.5 mm
Stub Shaft Length for Coupler Engagement	6 mm

MOTOR MOUNT LENGTH (X)

Compact Series System	X	
	NEMA 17 42 mm	NEMA 23 56 mm
	53.7 mm	54.3 mm

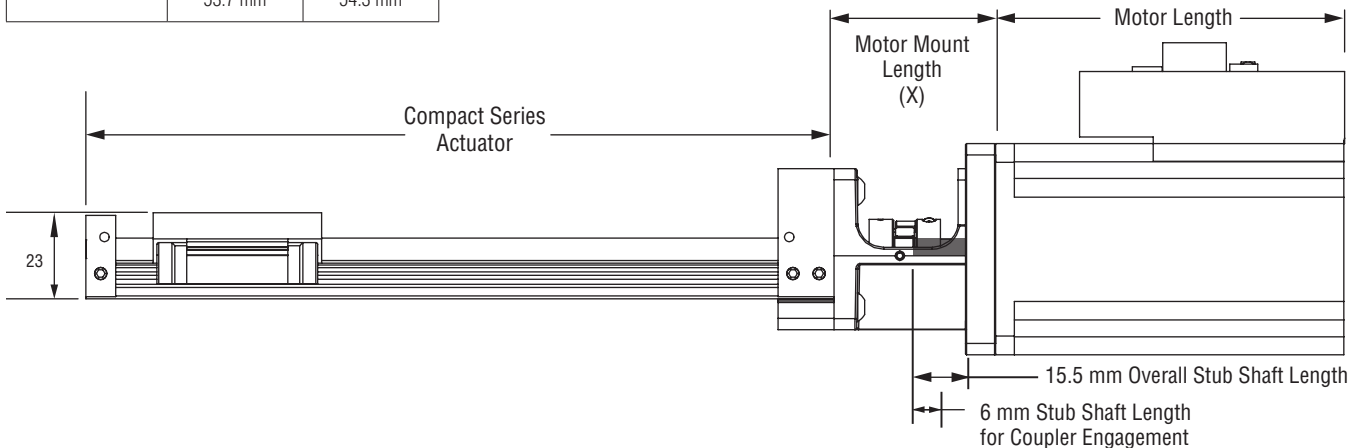

Motor Mount Assembly Procedure—Page 20



Motor Mount Option Motor Plate Dimensions

MOTOR SIZE: NEMA 17 (42 MM)

- Material: Anodized aluminum

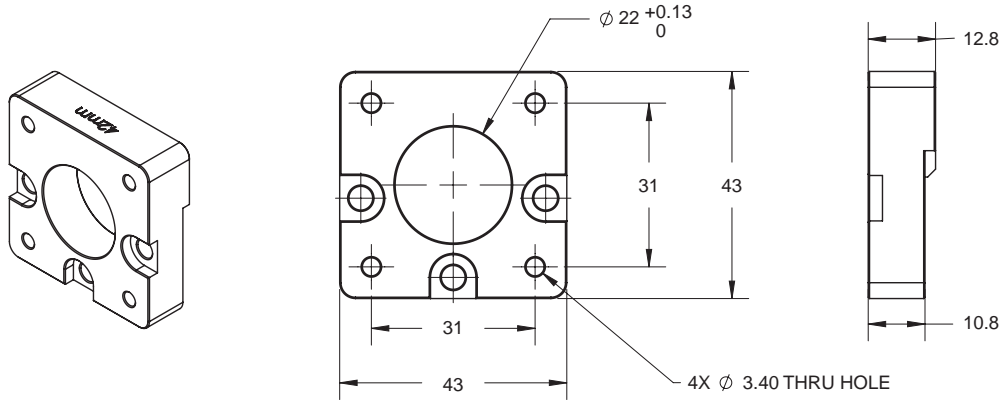

MOTOR SIZE: NEMA 23 (56 MM)

- Material: Anodized aluminum

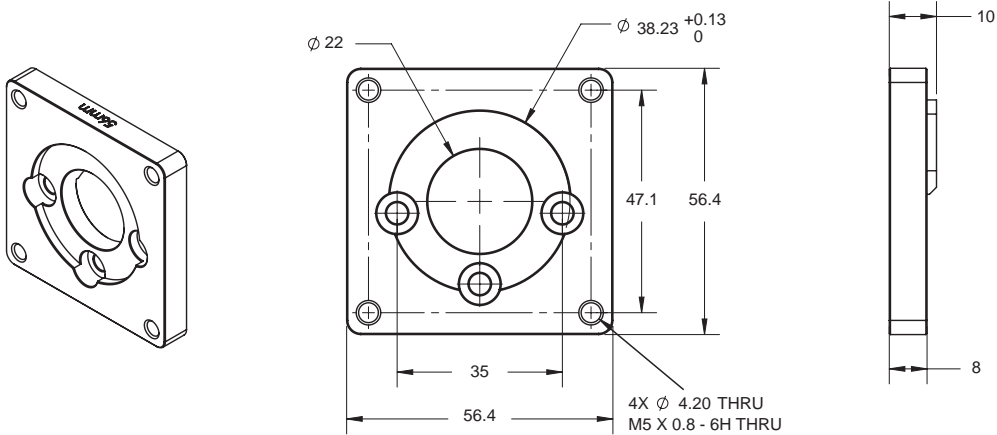

System Ordering Information—Page 13



Motor Mount Details—Page 15



Blank Plate & Main Frame Dimensions **Motor Mount Option**

• BLANK PLATE

- Intended use: To give customers the ability to machine the plate to match non-standard motor configurations
- Material: Anodized aluminum
- Tip: It is best to locate from the center hole when machining hole pattern for motor attachment.

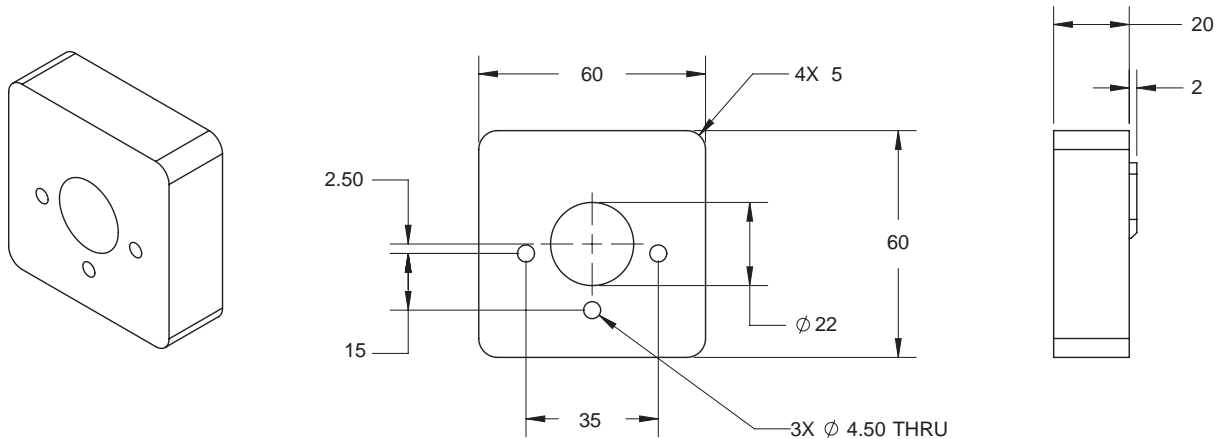

MAIN FRAME

- Material: Die cast aluminum, clear chromate

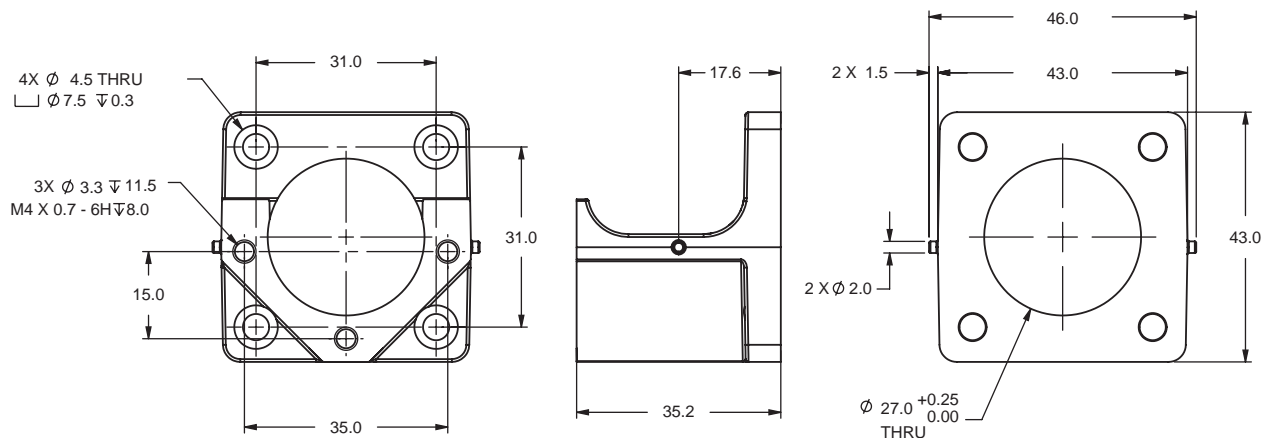
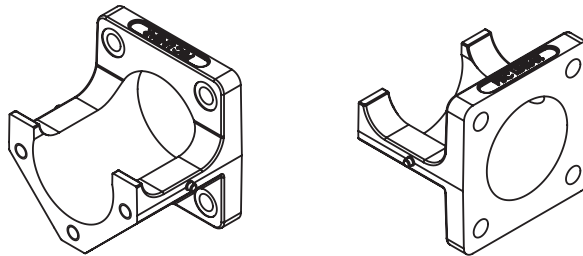



User Manual

USER MANUAL TABLE OF CONTENTS

Safety

Tips for Safe Installation and Operation 18

Motor Mount Option

Coupler 19

Assembly 20

Maintenance

Lubrication 21

TIPS FOR SAFE INSTALLATION AND OPERATION

- Only qualified personnel should transport, assemble, operate, and maintain this equipment.
- Always wear appropriate personal protection equipment, such as safety glasses and hearing protection.
- Read and observe the installation, operating, and safety instructions provided by the manufacturer. Incorrect handling and operation may result in damage to equipment and personal injury.
- Comply with all installation specifications and requirements to ensure proper setup.
- Provide a flat and stable mounting surface.
- Be sure sufficient space is provided to permit full carriage travel with no hard stops.
- Be sure power is OFF before performing actuator maintenance.
- The unit should be checked regularly for worn or damaged components. Follow recommended service intervals and replace defective parts immediately. Always replace parts with the same make and model as the original.
- Be aware that most actuator configurations are not self-braking. A load can move if the drive force is disconnected, or if drive train components are detached. This is particularly true for vertical applications. The load should be secured prior to service. Consider installing an electromechanical power-off brake in vertical configurations to prevent potential damage or personal injury.
- Actuators should be wiped down occasionally to keep them clean. Use fluids sparingly and be sure none seeps inside. Do not use strong or harsh cleaning agents.
- Always test run actuators after maintenance work is completed.
- Do not back-drive the lead screw by moving the carriage by hand.

MOUNTING TIPS

- Mount the Compact Series through the holes in the rail
- Counter bores accommodate M3 SHCS
- The number of counter bores varies with the length of rail





Motor Mount & Coupler Information **User Manual**

COUPLER

- Compact Series motor mounts are designed to work optimally with the R+W EKL2 coupler
- Other couplers can be used under the following conditions:
 - Maximum O.D. = 25 mm
 - Maximum length = 26 mm
- Coupler should be sized per the Compact Series actuator.

CAUTION

Verify coupler bore diameters and depths will accept both actuator stub shaft and motor shaft.

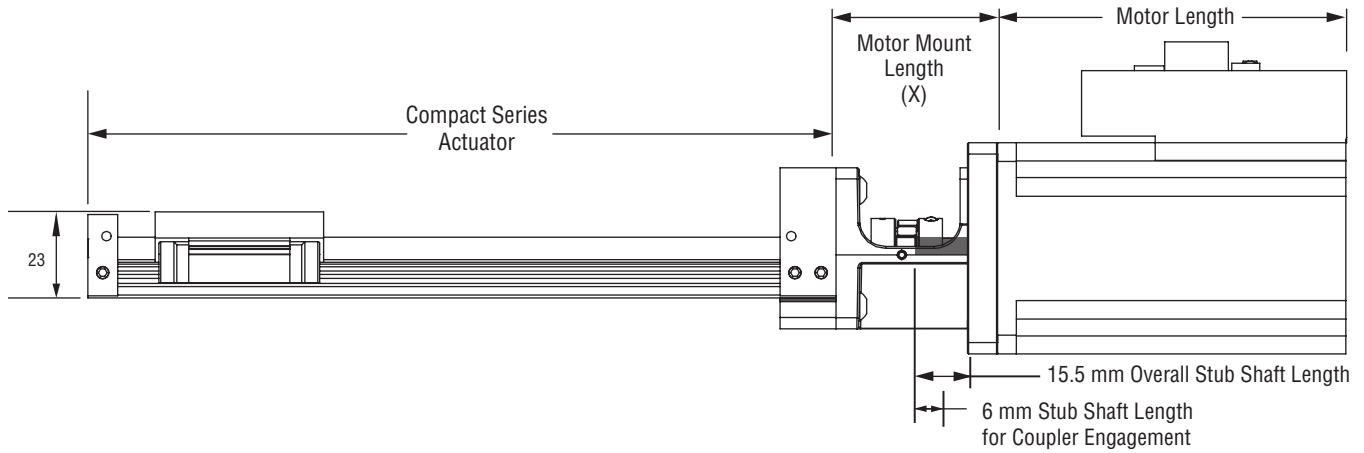

STUB SHAFT DIMENSIONS

Stub Shaft Diameter	3.5 mm
Overall Stub Shaft Length	15.5 mm
Stub Shaft Length for Coupler Engagement	6 mm

MOTOR MOUNT LENGTH (X)

	X	
Compact Series System	NEMA 17 42 mm	NEMA 23 56 mm
	53.7 mm	54.3 mm



User Manual Motor Mount Assembly

MOTOR MOUNT ASSEMBLY

Components:

- Base actuator unit
- Motor (customer supplied)
- Motor Mount Kit
 - Motor Plate
 - Main Frame
 - Cover
- Coupler (customer supplied) R + W EKL2 recommended

Fasteners: (9) M4 x 12 mm SBHCS (supplied by PBC Linear),
(4) Customer supplied motor fasteners (See Table 2)

Tools Required: Hex Key (See Table 1)

Suggested Thread Locker: Blue Loctite® 242 or equivalent

TABLE 1

Hex Key Size Needed:

- M3 SHCS = 2.5 mm Driver
- M4 SBHCS = 2.5 mm Driver
- M5 SHCS = 4 mm Driver

TABLE 2

Customer Supplied Fasteners:

- NEMA 17 Motor = M3 x 0.5 SHCS
- NEMA 23 Motor = M5 x 0.8 SHCS
- 60 mm Servo Motor = M5 x 0.8 SHCS

TABLE 3

Fastener Torque Values:

- M3 SHCS = 8-10 in/lb [1.0-1.2 Nm]
- M4 SBHCS = 17-21 in/lb [2.0-2.4 Nm]
- M5 SHCS = 37-45 in/lb [4.2-5.1 Nm]

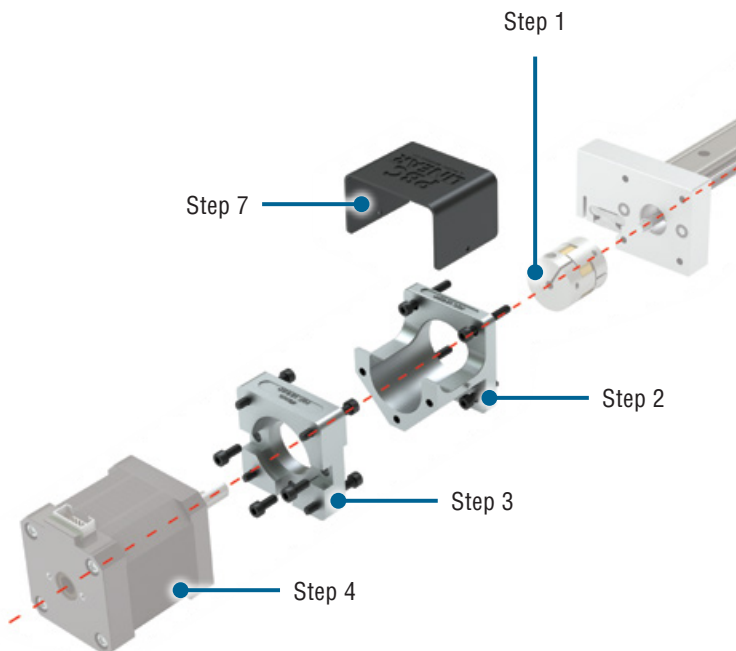

ASSEMBLY STEPS

1. Slide coupling onto shaft and leave loose.
2. Install main frame to actuator end block using (4) M4 x 12 mm SBHCS. Snug fasteners, but do not tighten.
3. Install motor plate to main frame using (3) M4 x 12 mm SBHCS. Apply blue Loctite® 242 or equivalent threadlocker and torque to 17-21 in/lb [2.0-2.4 Nm] (See Table 3).
4. Install motor to motor plate with customer supplied fasteners (See Table 2) and install shaft into coupling. Snug fasteners, but do not tighten.
5. Check for proper shaft engagement on both sides (per coupler manufacturer specs).
6. Once system is aligned, final torque all fasteners appropriately (See Table 3).
7. Install cover on pins in casting (snaps in place).



Lubrication **User Manual**

INITIAL LUBRICATION DURING INSTALLATION

Some PBC Linear systems are shipped with a preservative lubrication applied to the raceways. If so, additional lubrication should be applied during installation. Proper lubrication dissipates heat, increases service life, and reduces friction, wear, and corrosion. Recommended lubricants are listed where applicable, but there are some lubricants which **SHOULD NOT** be used on any configuration.

DO NOT USE: WD40; motor oil; oils with additives; moly or other filled greases; PTFE sprays, oils, or greases; or sprays containing fluorocarbons or silicone.

RECOMMENDED LUBRICANTS

Plain Bearing (GST - Gliding Surface Technology)

Recommended Lubricants: way lube oils, lightweight oils, 3-IN-ONE® oils, and lightweight petroleum-based greases. The PTFE coated lead screw and polymer nut require no lubrication during normal operation, but should be routinely inspected for damage and wear. In certain applications, however, an external lubricant may be desirable. Contact a PBC Linear applications engineer for guidance regarding additional lubrication.

Profile Rail (PRT - Profile Rail Technology)

Recommended Grease: Synthetic oil based lithium-soap grease with an ISO VG32-100 viscosity.

Recommended Oil: Synthetic oil CLP or CGLP based on DIN 51517, or HLP based on DIN51524.

Viscosity range should be ISO VG32-100.

RELUBRICATION

Linear guide raceways should be relubricated periodically with oil or grease. Recommended lubricants are listed where applicable, but there are some lubricants which **SHOULD NOT** be used on any Compact Series configuration.

DO NOT USE: WD40; motor oil; oils with additives; moly or other filled greases; PTFE sprays, oils, or greases; or sprays containing fluorocarbons or silicone.

The relubrication interval is dependent on many operating and environmental conditions, such as load, stroke, velocity, acceleration, lubrication type, mounting position/orientation, UV exposure, temperature, and humidity. The actual lubrication interval should be determined by tests conducted under actual application conditions.

While the actual relubrication intervals are application specific and determined only through testing, the following “first check” guidelines can typically be used as a starting reference point under “normal” conditions:

Relubrication every 1000 km; 50000 cycles; or six months (whichever occurs first)

Extended Lubrication Interval

Relubrication every 2500 km; 100000 cycles; or one year (whichever comes first)

Worldwide Headquarters
PBC Linear
A Pacific Bearing Co.

6402 E. Rockton Road
Roscoe, IL 61073 USA

Toll-Free: 1.800.962.8979

Fax: 1.815.389.5790

sales@pbclinear.com

www.pbclinear.com



A PACIFIC BEARING CO.

www.pbclinear.com

European Branch
PBC Lineartechnik GmbH
A Pacific Bearing Co.

Röntgenstr. 8
40699 Erkrath, Germany

Telefon: 0049 2104 957440 0

Fax: 0049 2104 957440 9

info@pbclinear.de

www.pbclinear.de

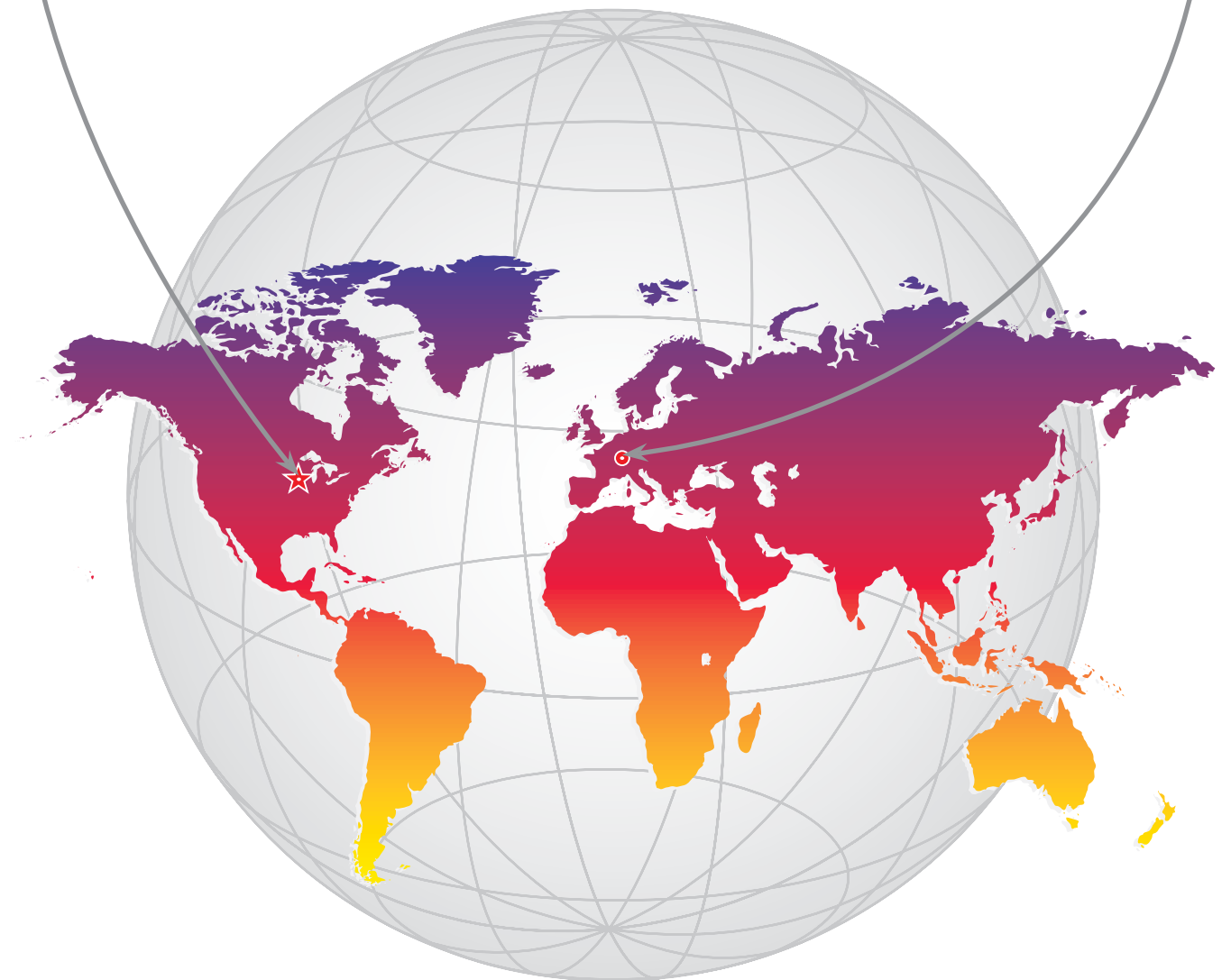

PBC Linear has a global network of distributors with thousands of locations worldwide.
Visit www.pbclinear.com to find a distributor near you.

DISTRIBUTED BY